

SPECIFICATIONS	
Bore	34mm
Stroke	29.0mm
Displacement	26.33cc
Weight	930g
Practical rpm	2,000 - 11,000rpm

fig.1

FEATURES

The DZ160 was developed for serious aerobatics competition and large IMAC style aircraft. It differs from previous YS Engines in that it does not use a high pressure fuel system but rather a true fuel pump.

*Crankcase supercharging system unique to YS 4 stroke engines

*Fuel injected

*Convenient fuel pump adjustment

*High horsepower output with long service life

GLOW PLUG

Select the most appropriate glow plug from those designed specifically for 4 cycle engines. Glow plug selection greatly affects the maximum engine output and low idle. If RPM's decrease or stop when the booster cord is removed, replace the plug. We recommend the YS#4 plug for maximum performance. These are available from YS Parts & Service or your favorite dealer.

INSTALLATION

WE RECOMMEND THAT THIS ENGINE BE MOUNTED ON A SHOCK ABSORBING SOFT MOUNT

- 1 Connect the engine to the tank as shown in fig.1. The recommended fuel tank size is 18 to 24 oz. A standard clunk type fuel tank may be used. If this type of tank is used, you must use the special clunk supplied with the engine. Please note that with this clunk, all of the fuel cannot be used from the tank. As soon as any part of the clunk becomes exposed, the engine will stop due to air entering the fuel pump.
- 2 Always use a fuel filter. We recommend YS filter (6720). With this filter, you must remove the cloth portion of the filter and leave both the metal filter screens in place.

PROPELLER INSTALLATION

Due to the high output power of the DZ160 engine, it is supplied with a double locknut system for added safety. If you use any other type of spinner or prop nut device, make sure it is of the double nut type.

- 1 Mount the propeller and tighten the rear nut. Next, tighten the front nut as shown in fig.2. The rear nut has an offset shoulder so the front nut will secure itself to the rear nut.
- 2 Select a good quality propeller that will allow the engine to run at maximum speed between 7,800 to 9,000 rpm range. We recommend sizes 16x13 to 17x12. Other prop sizes may be used as long as the correct rpm range.

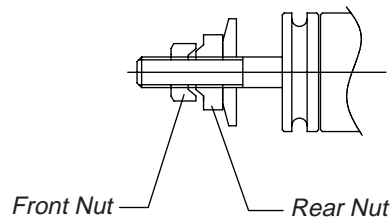

fig.2

START UP

- 1 Always break the fuel line between the fuel filter and the tank for filling. This will help to prevent dirt from entering the fuel pump. To prevent flooding the engine, clamp the fuel line with a hemostat or clip where it enters the fuel pump.
- 2 Open the high speed needle 2 turns from the closed position. The engine should run very rich with the recommended fuel and glow plug. We recommend YS 20/20 fuel (20% nitro / 20% oil) which is available from several manufacturers.
- 3 **An electric starter is mandatory for starting this engine.** Attempting to hand start this engine is difficult and dangerous.
- 4 Close the throttle to the idle position and connect the glow driver. The engine is now ready for starting.

DO NOT ATTEMPT TO START ENGINE AT FULL THROTTLE AS THIS IS VERY DANGEROUS. ALWAYS USE EXTREME CAUTION WHEN ENGINE IS RUNNING.

BREAK-IN

To maximize engine performance and increase durability, please follow this break-in procedure.

- 1 Use the same size (or slightly smaller) propeller than you intend to use in flying.
- 2 Use a good quality fuel containing 15% to 30% nitro, and oil content of 20% to 24%. Synthetic oil only. If you use castor oil, no more than 2% is recommended.
- 3 **DO NOT USE FOUR CYCLE FUEL DUE TO LOW OIL CONTENT.** After the engine has started, slowly bring the throttle up to full. Set high speed needle so it is running at a good rich setting without the glow driver.
- 4 After the initial 20 minute break-in, mount the engine in the aircraft and set the high speed to a richer than normal setting for the first 10 flights. This will help to lubricate all moving parts.

HIGH SPEED NEEDLE ADJUSTMENT

- 1 Adjustment of the high speed is done by the carburetor needle valve. When the needle valve is turned clockwise, the mixture is leaner. When it is turned counter-clockwise, the mixture is richer. A good starting position for the high speed needle valve is 2 turns open from the fully closed position. At this setting the engine will be very rich and may die when you remove the glow driver. If this happens, turn the needle valve in 1/2 turn and try again. The final running setting for the high speed needle will be approximately 1 to 1-1/2 turns open from fully closed.
- 2 When the engine is started, open the throttle gradually. Next, find the peak position (highest RPM) by adjusting the needle valve. Then the needle valve should be opened approximately 1/8 - 1/4 turns from full RPM to achieve best performance.

REGULATOR ADJUSTING

DO NOT ATTEMPT TO ADJUST THE REGULATOR SCREW WITH THE ENGINE RUNNING. STOP THE ENGINE BEFORE ADJUSTING THIS SCREW

The low speed adjustment is the regulator screw on the front of the engine. Turning the screw clockwise will richen the idle mixture, and counter-clockwise will lean the idle mixture. It is preset at the factory but may require further adjustment depending on fuel and conditions in your areas.

- 1 Wait until the engine is up to operating temperature before adjusting the idle mixture
- 2 Close the throttle gradually to an idle (approximately 2,200 rpm). Let it idle for 15 -20 seconds and then slowly advance the hrottle. The adjustment is correct when low to high speed has a smooth transition.
- 3 If the engine is running rough at idle or too rich, turn the regulator adjustment counter-clockwise to lean out the low end.
- 4 If the engine speeds up at idle, the low speed mixture is too lean. Turn the low speed regulator adjustment clockwise to richen the mixture.

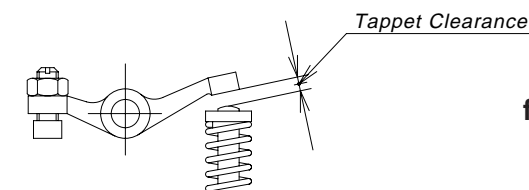

fig.3

TAPPET ADJUSTMENT

Tappet clearance is preset at the factory. Adjustment, if you needed, should be checked after the initial break-in. For maximum performance, valves should be checked as normal maintenance.

- 1 Clearance adjustment should be done when the engine is cool.
- 2 The proper clearance should be set at not more than 0.002" maximum. The adjustment is achieved by loosening the lock nut (fig.3) and turning the adjustment screw. The engine must be at top dead center on the compression stroke before any adjustments are made. This engine runs best with the valves set at a tight setting. If the valves are set too loose, power will be affected.

CAM GEAR TIMING

If for some reason you have to disassemble your engine, please follow these important steps on reassembling the cam gear.

- 1 Remove the carburetor and backplate assembly. Notice the impression mark or dot opposite the rod journal on the crankshaft. This mark is to point straight down or lined up with the outer case seam line at the bottom
- 2 Reinstall the cam with the dot facing you and pointing slightly to the left. This will allow the cam to turn to the right when properly installed. The dot should be pointing straight up when cam is fully installed. Reinstall cam cover and timing is now set.

FUEL PUMP

If you must disassemble the fuel pump to change the diaphragm or to clean, take care that the valves and springs are replaced in exactly the same manner in which they were removed. Do not disassemble the pump needlessly. Use care with filtering your fuel and keeping the entire fuel system in good working order. It will help to prevent fuel pump problems.

DZ160 Parts list

#	Part#	Description	QTY
1	F4001	Crankcase	1
2	F2002	Valve cover	1
3	F1203	Head cover gasket	1
4	F1204	Valve cover screw set	2
5	F4005	Head gasket	1
	F2006A	Head assembly	
6	F2006	Cylinder head	1
7	F1407	Intake valve	1
8	F1408	Exhaust valve	1
9	F1409	Valve spring set	2
10	F1410	Spring retainer set	2
11	F1411	Valve spring retainer clips	4
12	F1212	Rocker arm set	2
13	F2013	Intake tappet adjusting screw	1
14	F2014	Exhaust tappet Adjusting screw	1
15	F1214	Tappet adjusting lock nuts	2
16	F1215	Rocker arm shaft	1
17	F1216	Rocker arm shaft screw	1
18	F1217	E ring set	2
19	F1518	Head bolt set	5
20	F4020	Crankshaft	1
21	F1475	Crankshaft ring	1
22	F4022	Cylinder liner	1
23	F4023	Piston	1
24	F4024	Wrist pin	1
25	F1523	Wrist pin retainer set	2
26	F4026	Piston ring	1
27	F2027	Connecting rod	1
	F4128A	Back plate assy.	
28	F4128	Back plate	1
29	F4029	Disc valve	1
30	F4030	Disc valve pin	1
31	F4031	Disc valve screw	1
32	F1230	Back plate gasket	1
33	F2132	Carburetor insulator	1
34	F2192	Insulator gasket	1
35	F2133	Back plate screw set	6
36	F1232	Cam gear cover	1
37	F1233	Cam gear cover O-ring	1
38	F1234	Cam gear cover screws set	2
39	F2036	Cam	1
40	F2137	Cam followers	1
41	F2040	Exhaust push rod	1
42	F2041	Push rod cover	1
43	F1239	Push rod cover O-ring	4
44	F1240	Front bearing	1
45	F9122	Front bearing oil seal	1
46	F1341	Rear bearing	1
47	F1242	Cam gear bearing set	2
	F2147A	Pump assembly	
48	F2047	Regulator body	1
49	F1245	Regulator adjusting screw	1
50	F1246	Regulator adjusting screw O-ring	1
51	F2050	Diaphragm	1
52	F2051	Regulator spring	1
53	F2052	Regulator screw set	2
54	F2153	Fuel pump body	1
55	F2054	Pump valve	2
56	F2055	Pump valve spring	2
57	F2056	Pump plate	1
58	F2057	Pump screws	2
59	F2058	Pump gasket	1
60	F2186	Plunger	1
61	F2187	Pump insulator	1
62	F2188	Insulator O ring	1

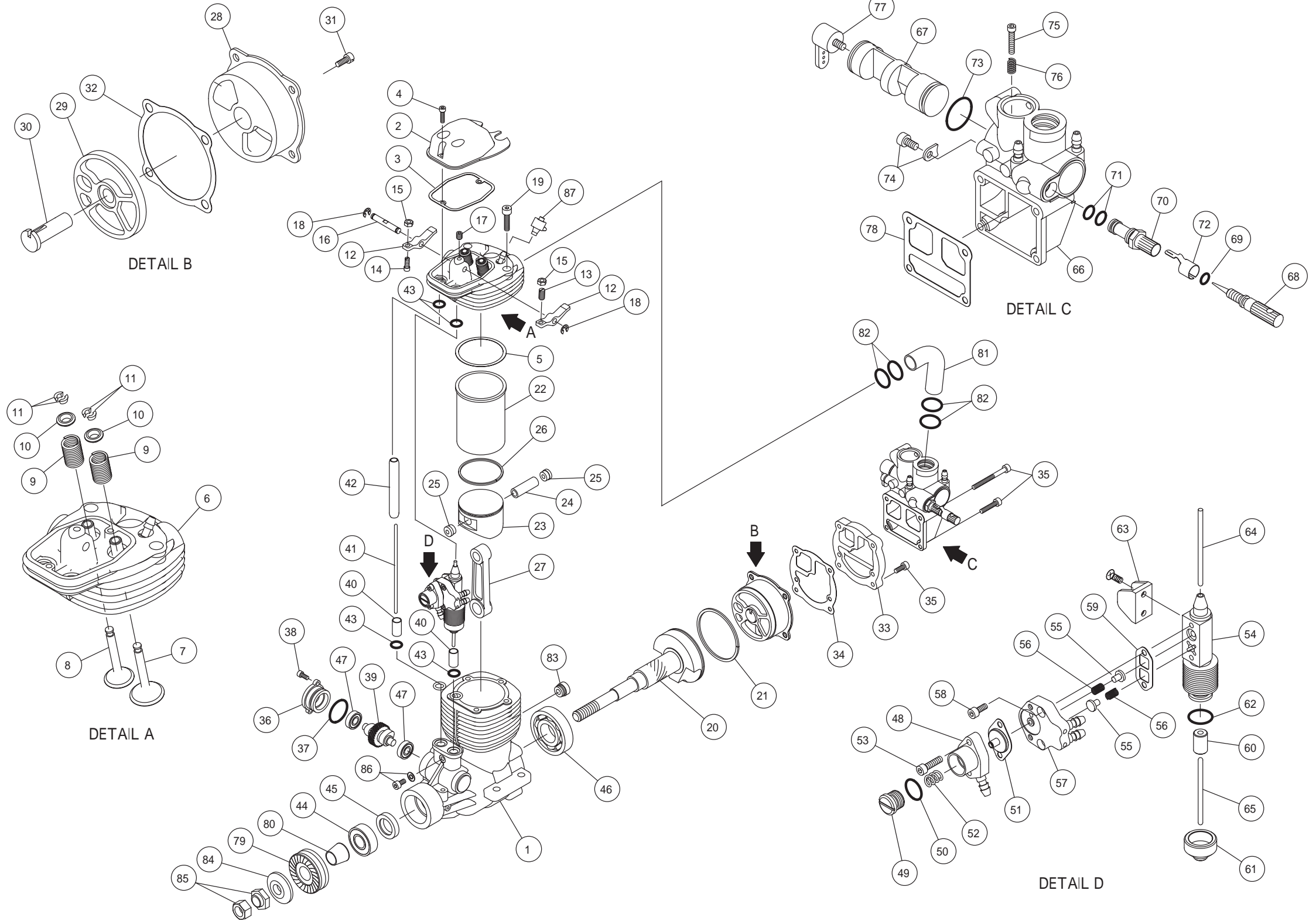

63	F2059	Pump bracket	1
64	F2190	Upper push rod	1
65	F2191	Lower push rod	1
	F2161A	Carburetor assembly	
66	F2161	Carburetor body with throttle barrel	1
	F1545S	Needle valve assembly	
68	F1545	High speed needle valve	1
69	F1546	High speed needle valve O-ring	1
70	F1555	High speed needle seat	1
71	F1556	Needle valve socket O-ring set	3
72	F1557	Needle valve detent	1
73	F2168	Throttle barrel seal	2
74	R6124	Throttle barrel retainer	1
75	F1258	Throttle stop screw	1

76	F1259	Throttle stop spring	1
77	F1260S	Throttle arm set	1
78	F2073	Carburetor gasket	1
79	F1564	Drive washer	1
80	F1565	Drive washer retainer	1
81	F1568	Intake pipe	1
82	F1269	Intake pipe O-ring	4
83	F1382	Wrist pin access plug	1
84	F1266	Propeller washer	1
85	F1267	Propeller nut set	2
87	F4088	Check valve	1
	F2182S	Gasket set	4
	F2282S	O ring set	16
	F2083	Fuel tank clunk	1



YAMADA MFG.CO.,LTD
67 Tsuchitori Inuyama Aichi 484-0917 JAPAN