

Safety Instructions

In order for you to use of the engine, please read through this instruction manual carefully. This instruction manual uses special words, if you have any difficulties for understanding, please ask the hobby shop you purchased or contact us directory.

1. Mount the propeller must use propeller nut supply with the engine.
2. Select a good quality propeller and follow instruction by manufactures.
3. Select a propeller size not increases practical rpm in the air.
4. Be sure not people standing front and sides of propeller while running.
5. Use electric starter to start the engine with idle position of the carburetor.
6. After start the engine, move behind of propeller and well adjust needle setting before you fly.
7. It becomes extreme high temperature while and after engine runs. Do not touch engine, exhaust header, muffler, and any parts attached to the engine while engine runs or before cool it down.
8. If engine runs not correctly, DON'T FLY!
9. Do not use this engine other than radio controlled airplanes. Can not use for radio controlled helicopters.
10. You have full responsibility while you operate the engine. Please be extra care for safety when never you operate the engine.

Installation

WE RECOMMEND THAT THIS ENGINE BE MOUNTED ON A SHOCK ABSORBING SOFT MOUNT

- 1 Connect the engine to the tank as shown in fig.1. The recommended fuel tank size is 18 to 24 oz. A standard clunk type fuel tank may be used. If this type of tank is used, you must use the special clunk supplied with the engine. Please note that with this clunk, all of the fuel cannot be used from the tank. As soon as any part of the clunk becomes exposed, the engine will stop due to air entering the fuel pump.
- 2 Always use a fuel filter. We recommend YS filter (6720). With this filter, you must remove the cloth portion of the filter and leave both the metal filter screens in place.

Fuel

1. Use a good quality alcohol based model engine fuel containing 10% to 25% nitro, and oil content 5% to 25%. You can not use gasoline fuel.
2. When you filling the tank, disconnects Fuel Tube "A", or Fuel Tube "B" see "Fig.1" from connecting tube to filling. If you use "T" nipple on the fuel line to filling, use fuel stopper on the Fuel Tube "A" see "Fig.1" to avoid fuel in to the engine.

Propeller

1. Due to the high output power of the DZ175 engine, it is supplied with a double locknut system for added safety. Mount the propeller and tighten the rear nut. Next, tighten the front nut. The rear nut has an offset shoulder so the front nut will secure itself to the rear nut.
2. Please retighten propeller nut periodically.
3. Select a propeller that will allow the engine to run at maximum speed between 6,000 to 8,000 rpm range.
4. We recommend sizes 19X11 to 21X10. Other prop sizes may be used as long as the correct rpm range.

High Speed Needle Adjustment

- 1 Adjustment of the high speed is done by the carburetor needle valve. When the needle valve is turned clockwise, the mixture is leaner. When it is turned counter-clockwise, the mixture is richer. A good starting position for the high speed needle valve is 2 turns open from the fully closed position. At this setting the engine will be very rich and may die when you remove the glow driver. If this happens, turn the needle valve in 1/2 turn and try again. The final running setting for the high speed needle will be approximately 1 to 1-1/2 turns open from fully closed.
- 2 When the engine is started, open the throttle gradually. Next, find the peak position (highest RPM) by adjusting the needle valve. Then the needle valve should be opened approximately 1/8 _ 1/4 turns from full RPM to achieve best performance.

Brake-in

1. Starting the engine with high speed needle valve 2 turns open from the fully closed position and idle position on carburetor.
2. After start the engine, increases rpm gradually by operates throttle control up and down. Do not suddenly open throttle to fully open position.
3. If mixture is too rich and miss firing, turn clockwise high speed needle valve to leaner mixture.
4. Brake-in the engine one or two tanks (600cc or 20oz. tank) of fuel on the ground with richest possible mixture setting.

Idling adjustment

1. To get 1,200rpm to 2,000rpm idling.
2. When the regulator is turned counter-clockwise, the idle mixture is leaner. When the regulator is turned clockwise, the idle mixture is richer. Adjust regulator by turn 45 degree at a time.
3. If idle mixture is too rich, gradually rpm drops and stops after continuous idling. If engine stops when you change attitude of airplane on the ground also too rich on idle mixture. If mixture is too lean on idle, rpm is go up and down and not keep stable when you make continuous idle.

Glow Plug

Select the most appropriate glow plug from those designed specifically for 4 cycle engines. Glow plug selection greatly affects the maximum engine output and low idle. If RPM's decrease or stop when the booster cord is removed, replace the plug. We recommend the YS#4 plug for maximum performance.

Tappets Adjustment

1. Tappet clearance is preset at the factory.
2. Clearance adjustment may need after first one hour running time due to initial wear. After first adjustment, clearance should be checked as normal maintenance for every 10 hours running for maintain maximum performance.
3. Clearance adjustment should be done when the engine is cool.
4. The proper clearance should be set at 0mm (0.000") to 0.1mm (0.004"). The adjustment is achieved by loosening the lock nut see "Fig.2" and turning the adjustment screw see "Fig.2". The engine must be at top dead center on the compression stroke before any adjustments are made. This engine runs best with the valves set at a tight setting. If the valves are set too loose, power will be affected.

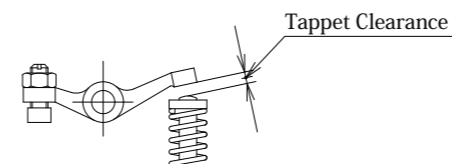

Fig2

Cam Gear Timing

If for some reason you have to disassemble your engine, please follow these important steps on reassembling the cam gear.

1. Remove the carburetor and back plate assembly. Notice the impression mark or dot opposite the rod journal on the crankshaft.
2. This mark is to point straight down or lined up with the outer case seam line at the bottom and hold crankshaft securely.
3. Reinstall the cam with the dot facing you. After you fully installing cam and then check dot should be pointing straight down will give you right timing.

Operation of YS Super Mount (Option)

1. It is hold by 4 screws, 2 on the front ring and 2 on the rear soft mount. There are two different height of spacer we provide.
A set spacer (MN110S) : 10mm thickness
B set spacer (MN111S) : 4mm thickness
2. Please be sure not to hit any part of the fuselage by the engine after it installed.
3. If damper oil is leaked, refill TAMIYA damper silicon oil #600. Damper is a consumption parts, please exchange if you find worn or some defect.

Cleaning

This engine is using silicon gaskets, "O" rings etc. Please use methanol or model engine fuel for cleaning. Do not use Kerosene, Gasoline, Machine oil, Automobile parts cleaner or house hold lubricants to clean. It will harm silicon parts.

Engine Cooling

Be sure to secure cooling air for engine cooling. If it is not enough cooling air for the engine causes heat up the regulator and carburetor to make vaporized or percolates the fuel and will get deteriorations of engine performance or stop the engine. Please read carefully below for provision.

1. Please open air intakes and outlets as big as possible.
2. Take off cowling when you make long engine adjustment included idle adjustment. When air temperature is high, it may heat up the regulator and carburetor to make vaporized or percolate the fuel even with out cowling. If it happens, wait till engine well cooling down before you restart and adjust.

Rusting provision

Do not leave fuel in the engine after you finished for day. If you store the engine long period of time, few drops (about 1cc) of model engine lubricant oil from carburetor and clank several times. Do not use Automobile engine oil. They will not mix together with alcohol.

Parts and Repair Service

If you can not find repair parts form hobby shops, you can order parts direct to our factory. We also do repair your engine at our factory. If you need repair service, please make detailed of states and send together with the engine.

Warranty

We strictly inspect each process of production from parts to final assemble for keep good quality. If a performance deteriorates or part fails due to a manufacturing error under normal usage will repair no charge with in 1 year starting from the date of purchase. Warranty will not cover normal wear. Even with in 1 year warranty term, improper disassemble or assemble, under improper usage, any modification will avoid this warranty and there will be normal charge for parts and labors.

NO.	PART#	Description	QTY
1	E3001	Crankcase	1
2	F2002	Valve cover	1
3	F1203	Valve cover gasket	1
4	F1204	Valve cover screw set	2
5	F8205	Head gasket	2
E1206A		Head assembly	
6	E1206	Cylinder head	1
7	F1407	Intake valve	1
8	F1408	Exhaust valve	1
9	F8009	Intake valve spring	1
10	F8010	Exhaust valve spring	1
11	F1410	Spring retainer set	2
12	F1411	Valve spring retainer clips	4
13	F1212	Rocker arm	2
14	F2013	Intake tappet adjusting screw	1
15	F2014	Exhaust tappet adjusting screw	1
16	F1214	Tappet adjusting lock nuts	2
17	F1215	Rocker arm shaft	1
18	F1216	Rocker arm shaft screw	1
19	F1217	E ring set	2
20	F1518	Head bolt set	5
21	E3009	Crankshaft	1
22	F1475	Crankshaft ring	1
23	F8023	Cylinder liner	1
24	E3024	Piston	1
25	F8025	Wrist pin	1
26	F4026	Piston ring	1
27	E3027	Connecting rod	1
28	F8128A	Back plate assy.	1
29	F1230	Back plate gasket	1
30	F2132	Carburetor insulator	1
31	F2192	Insulator gasket	1
32	F2133	Back plate screw set	6
33	F1232	Cam gear cover	1
34	F1233	Cam gear cover O ring	1
35	F1234	Cam gear cover screw set	2
36	F2036	Cam gear	1
37	E1236	Cam followers	2
38	F2040	Exhaust pushrod	1
39	F2041	Push rod cover	1
40	F1239	Push rod cover O rings	4
41	F1240	Front bearing	1
42	F9122	Front bearing oil seal	1
43	F1341	Rear bearing	1
44	F1242	Cam gear bearing set	2
F8048A		Pump assembly	
45	F2047	Regulator body	1
46	F1245	Regulator adjusting screw	1
47	F1246	Regulator adjusting screw O ring	1
48	F2050	Diaphragm	1
49	F2051	Regulator spring	1
50	F2052	Regulator screw set	2
51	F8054	Fuel pump body with plunger	1
52	F2054	Pump valve	2
53	F8056	Pump valve spring	2
54	F2056	Pump plate	1
55	F2057	Pump screws	2
56	F2058	Pump gasket	1
57	F2187	Pump insulator	1
58	F2188	Insulator O ring	1
59	F2059	Pump bracket	1
60	F2190	Upper push rod	1
61	F2191	Lower push rod	1
62	F8062	Pump cap	1

E3064A		Carburetor assembly	
63	E3064	Carburetorbody with throttle barrel	1
	F1545S	Needle valve assembly	
64	F1545	High speed needle valve	1
65	F1546	High speed needle valve O ring	1
66	F1555	High speed needle seat	1
67	F1556	Needle valve seat O ring set	3
68	F1557	Needle valve detent	1
69	E3069	Throttle barrel O ring	1
70	R6124	Throttle barrel retainer	1
71	F1258	Throttle stop screw	1
72	F1259	Throttle stop spring	1
73	F1260S	Throttle arm set	1
74	F2073	Carburetor gasket	1
75	F1564	Drive washer	1
76	F1565	Drive washer retainer	1
77	F8081	Intake pipe	1
78	F1269	Intake pipe O ring	4
79	F8083	Wrist pin access plug	1
80	F1266	Propeller washer	1
81	F2267	Propeller nut set	2
82	F2084	Wrist pin access screw	1
83	F4088	Check valve	1
	F2181S	Gasket set	5
	E3085S	O ring set	15
	F2083	Fuel tank clunk	1
	F8089	Tube holder	1

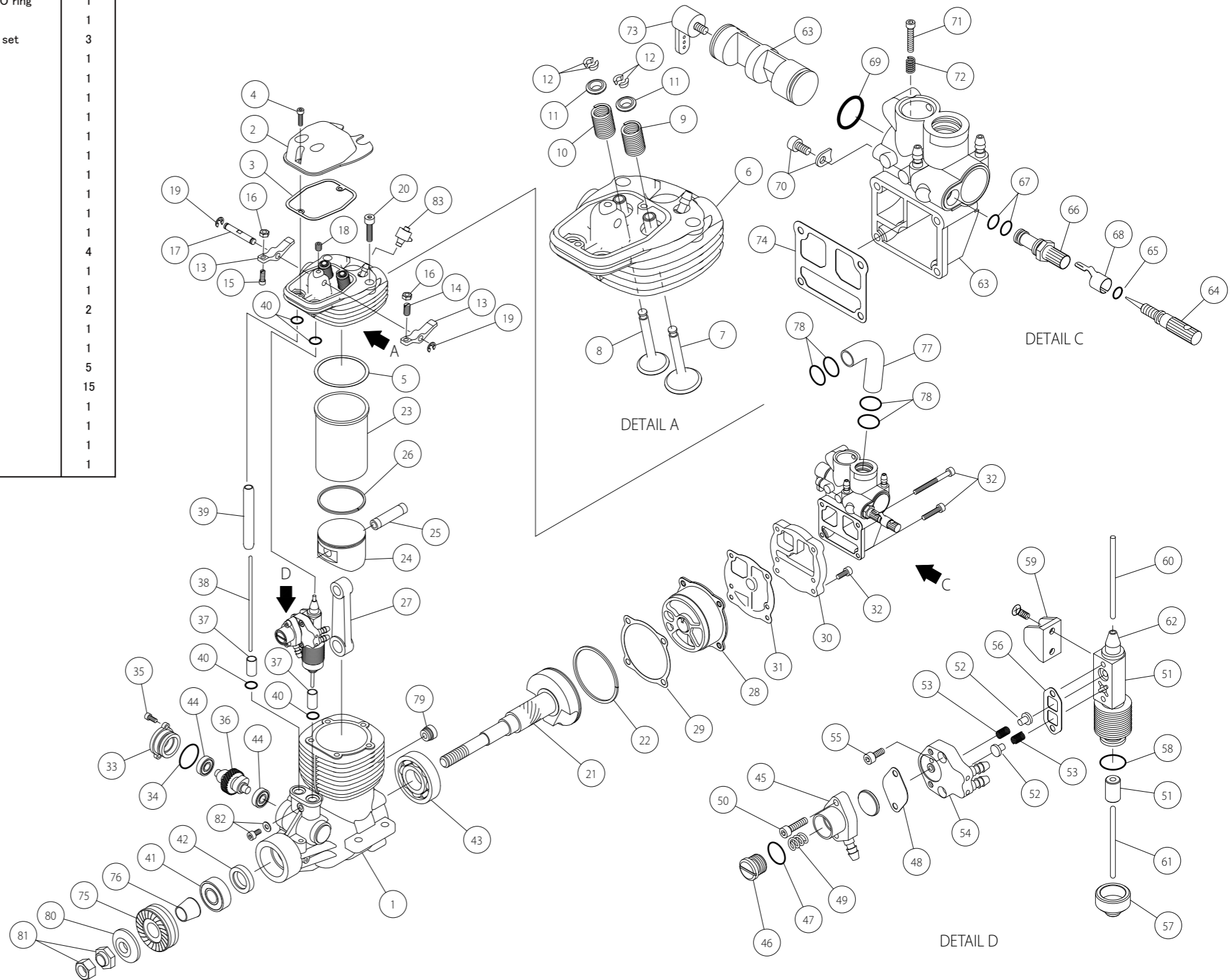

YAMADA MFG. CO.,LTD.

67 TUCHITORI, INUYAMA, AICHI, JAPAN 484-0917
TEL (0568) 67-0265/ FAX (0568) 67-7801