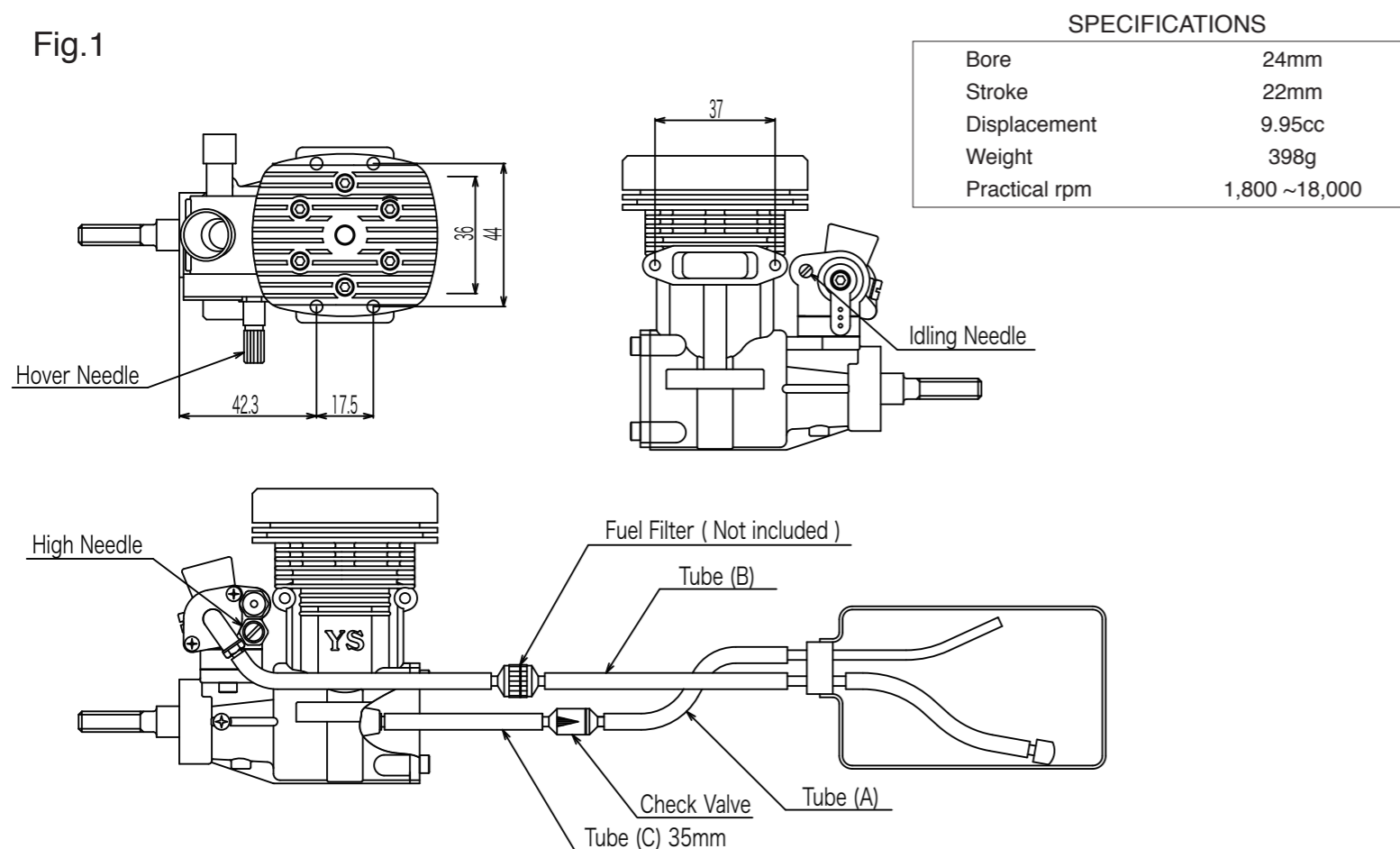

Fig.1



FEATURES

The 60SR is the latest in helicopter engine technology from YS.

- New stroke design for superior operation
- New carburetor design for easier adjustments.
- Factory preset fuel regulator.

INSTALLATION

1. The fuel lines should be connected to the fuel tank as shown in the above figure. Be careful to install the check valve in the correct direction. Since the tank is exposed to high pressures, be sure that all connections are tight to prevent pressures leakage.
2. Since the engine is sensitive to dirt in the fuel, a fuel filter must be used.
3. Tube(C) should be set exactly at 35mm between the engine and check valve. DO NOT use any other type of check valve. The check valve is designed exclusively for the 60SR.
4. Adjust your throttle linkage and curve using the alignment indentations on the carburetor body located on the throttle arm side of the carb body. PLEASE NOTE that the hover position is at 40% see FIG 2.

START UP

1. Always remove Tube(A) at the check valve first before fueling. The fuel tank is pressurized and you need to relieve the pressure first. Disconnect Tube(B) at the filter and fill the tank. Reconnect Tube(A) and (B).
2. From the fully closed (clockwise) position, turn the needle valves counter clockwise as follows.
3. Close the throttle to the idle position and connect the glow plug driver. The engine is now ready for starting.

STARTING SETTING / OPERATING SETTING

- Hover Needle 2 times open / 1.0~2.0
- Idling Needle Factory Set (0.5) / 0.2~1.0
- High Needle Factory Set (1.5) / 0.5~2.0

BREAK-IN

It is not necessary to mount this engine on a set stand for break-in. However, the engine should be adjusted slightly on the rich setting (Hover Needle 2 times open) for the first few flights to insure proper break-in. Always use a good quality fuel which contain 15 ~30% nitro-methane and an oil content of 18 ~23% low viscosity oil.

NEEDLE VALVE ADJUSTMENT

Idle, Hover and High needle valves all work the same way. Turning the needles clockwise will lean the fuel mixtures and counter clockwise will richer the fuel mixtures.

1. Set needles as described in START-UP.
2. Start the engine and check idle. Adjust as needed.
3. Lift helicopter into a hover and check for the correct rotor RPM recommended by the kit manufacture. Once this is done take note of the amount of smoke being produced by the muffler. The mixture is correct for hover when there is a steady stream of smoke being produced.
4. Land the helicopter for approximately 20~30 seconds. Lift the helicopter into a hover again taking note of the transition from idle to hover. If the engine exhibits a large amount of smoke and the throttle response is sluggish, you will need to adjust the idle and or the hover needle leaner to achieved a smooth transition. If the engine detonates and the smoke is inconsistent or a small amount is produced, the mixture is too lean.
5. High Needle refines the fuel mixture for forward flights without affecting the hovering adjustment. After the engine is started and warmed up, lift-off into a hover and check that the engine is running smooth with a good trail of smoke. If everything is fine, open the throttle and enter forward flight. Take note of the amount of smoke like we did in a hover adjustment. It is correct when you see a noticeable steady smoke trail. Adjust the high-speed needle valve to obtain slightly rich but consistent setting.

STOPPING THE ENGINE

1. Fully close the throttle barrel to stop the engine.
2. As soon as the engine stops running, be sure that a fuel line clamp is used in Tube(B) to prevent fuel from flowing into the engine.
3. On the final flight of the day, the fuel line clamp should be used to stop the engine in order to prevent rust and corrosion.

FUEL AND GLOW PLUG

We have found that the fuel and glow plugs listed below will give the best engine performance.

Fuel Nitro 15~30% Oil 18~23%
Glow Plug YS #2 Enya #3 OS #8

IMPORTANT!

Silicone rubber is used in many parts of the YS engine. Use only glow fuel of methanol for cleaning. Gasoline and other volatile solutions will damage silicone if used.

WARRANTY

Strict quality control is implemented by our factory in all phases, from parts manufacturing to final assembly. If performance deteriorates or a part fails due to a manufacturing error, YS engine will repair or replace the engine at no charge in the period of one year from date of purchase. Warranty does not cover normal maintenance. Should the engine be modified, incorrectly assembled or abused, there will be a normal charge for parts and labor.

Fig.2

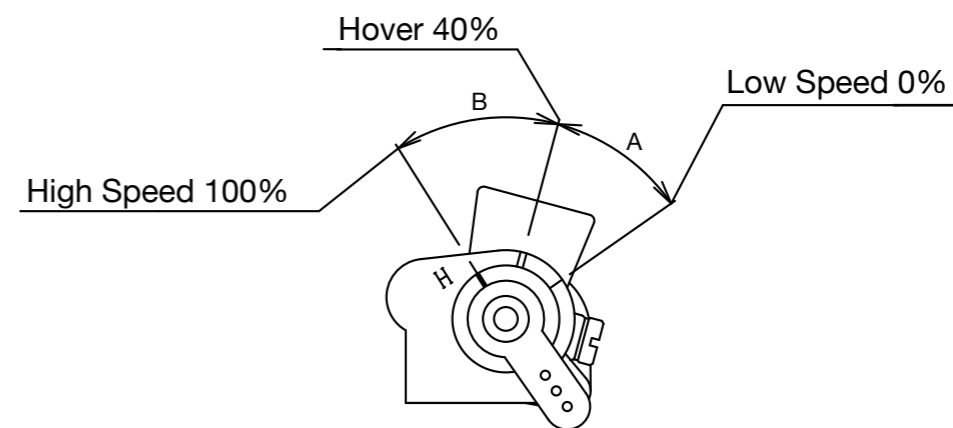

NO.	PART#	DESCRIPTION	QTY
1	R1001	Crankcase	1
2	R1002	Cylindr Head	1
3	R1003	Head Gasket	1
4	S1004	Head Screw Set	6
	R1005S	Liner and Piston Set	
5	R1005	Liner	1
6	R1006	Piston	1
7	R1007	Piston Ring	1
8	S1008	Wrist Pin	1
9	S2009	Wrist Pin Retainers	2
10	S1010	Con Rod	1
11	R1011	Crankshaft	1
12	R6211	Front Bearing	1
13	R6112	Rear Bearing	1
14	S1014	Drive Washer Spacer	1
15	S1015	Prop Nut	1
16	S2016	Back Plate	1
17	S1017	Back Plate O Ring	1
18	S1018	Back Plate Set Screws	4
19	S2019	Carburetor Body	1
20	S1020	Carburetor Gasket	1
21	S2021	Carburetor O Ring	2
22	S1022	Carburetor Insulator	1
23	S2023	Insulator Set Screws	4
24	S2025	Throttle Barrel	1
25	S2026	Throttle Barrel Set Screw	1
	S1027S	Hover Needle Set	
26	S1027	Hover Needle	1
27	F1546	Hover Needle O Ring	1
28	S1029	Hover Needle Socket	1
29	S1030	Hover Needle Socket O Ring	3
30	F1557	Needle Valve Detent	1
31	S5131	Idling Needle	1
32	S8133	Idling Needle O Ring	1
33	R1033	High Needle	1
34	R1034	High Needle O Ring	1
35	S2049	High Needle Socket	1
36	S2050	High Needle Socket O Ring	2
37	F1260S	Throttle Arm Set	1
38	R1038	Insulator O Ring	1
39	S2035	Carburetor Screws	2
40	S2036	Regulator Body A	1
41	S2037	Regulator Body B	1
42	S1038	Diaphragm	1
43	S1049	Regulator Valve	1
44	S1041	Regulator O Ring	1
45	S1044	Regulator Set Screws	2
46	S1045	Crankcase Plug	1
	S7144	Check Valve	1
	R1047	O Ring Set	13

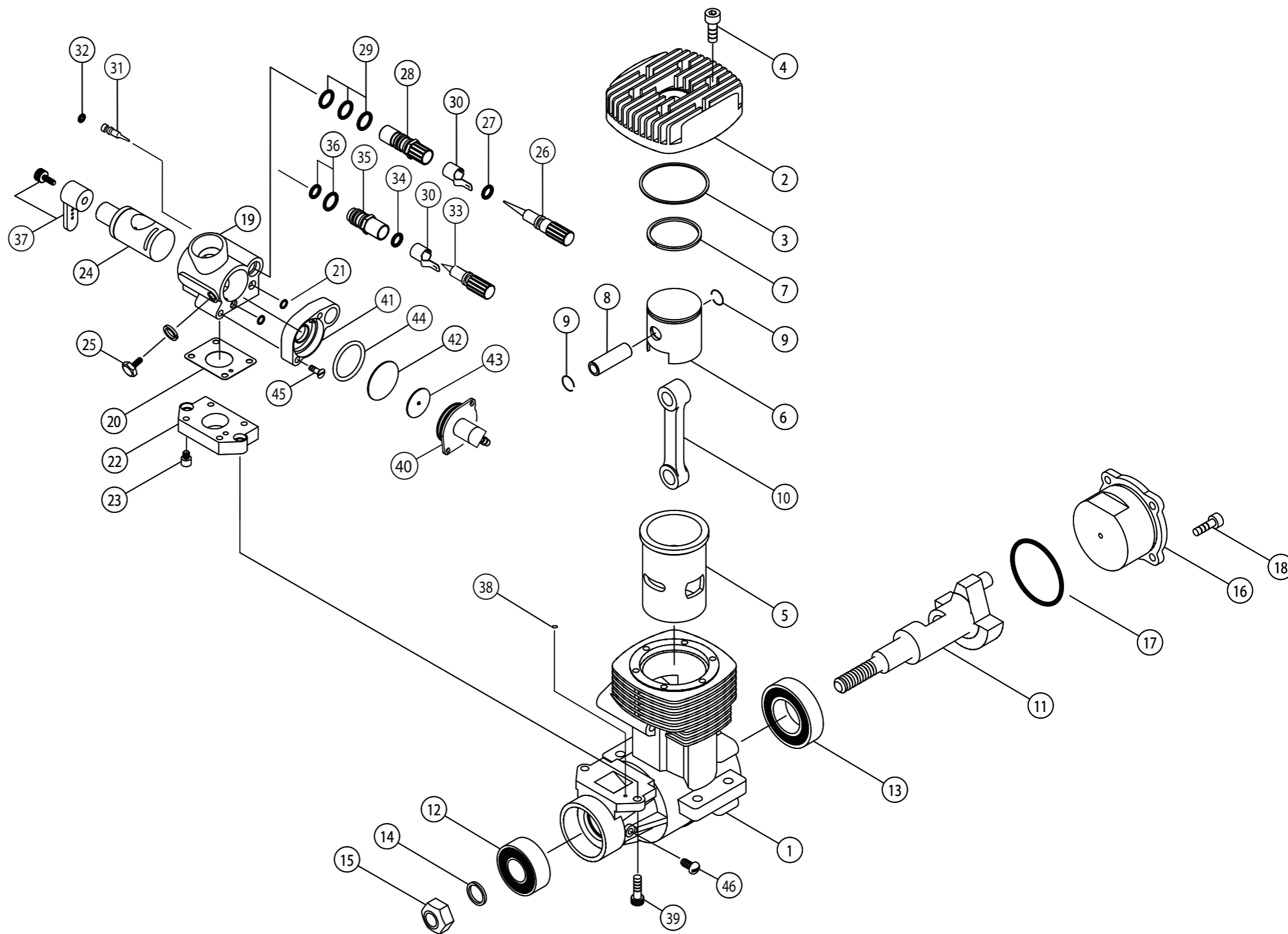

YAMADA MFG. CO., LTD.
67 Tsuchitori Inuyama, Aichi, 484-0917 JAPAN
tel: 81 568 67 0265 fax: 81 568 67 7801
<http://www.yspower.co.jp>